

ADDENDUM

ELECTRONIC

Super Vendor

WITH
COINCO
VALIDATOR

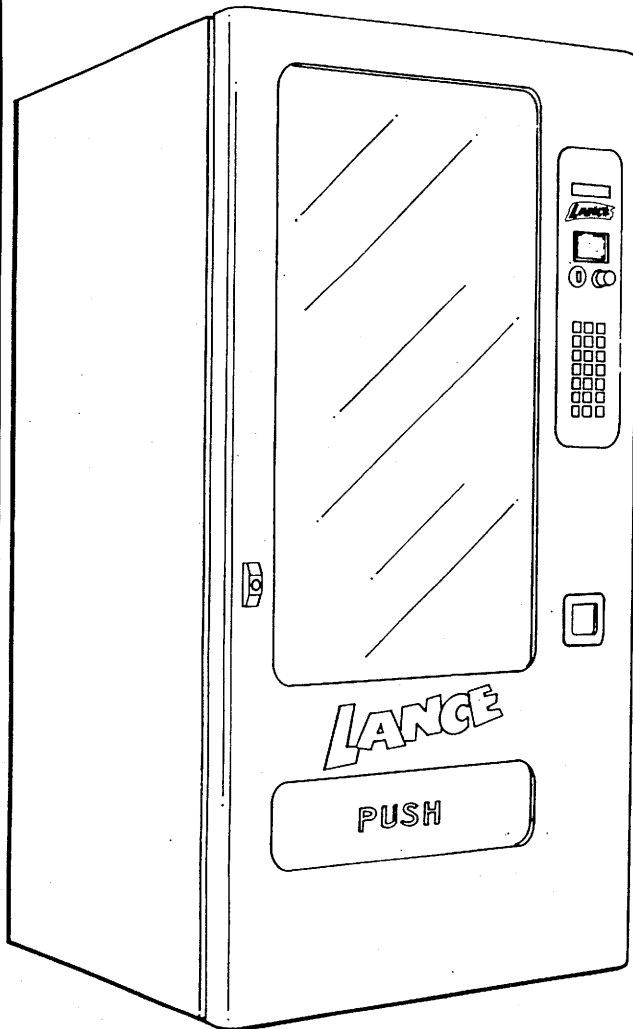

LANCÉ

23 Selection
Model 3053
Beginning S/N 804922

35 Selection
Model 3054
Beginning S/N 602271

Service and Parts Manual

May 1996

P/N 4203642-001

This is an addendum to the **Lance Electronic Super Vendor** Service Manual (P/N4203642) for models 3053 and 3054. The contents of this addendum will cover the changes to the Super Vendor that were made when the **Coinco Validator (#BA32SA)** replaced the Maka #NB-2, previously used in these vendors.

The BA32SA bill validator contains an option switch module allowing the unit to be customized to the requirements of an individual account. The following chart shows the functions of the option switches:

SWITCH	ON	OFF
1	High Security	Standard Acceptance
2	Accepts bills in one direction only (face up, green seal first)	Accepts bills in both directions (face up)
3	Serial or Parallel Interface	Pulse interface
4	\$20 Accept	\$20 Reject
5	\$10 Accept	\$10 Reject
6	\$5 Accept	\$5 Reject
7	\$2 Accept	\$2 Reject
8	\$1 Accept	\$1 Reject

All validators shipped from the factory will be set with switches #3 & #8 in the "ON" position. All other switches will be set to the "OFF" position. If you desire settings different from those set at the factory, follow the steps outlined below:

1. Remove power from the validator by turning the main power switch to the "OFF" position.
2. Remove the retaining screw that secures the logic board and strain relief. (see *Figure 1*)
3. Slide the logic board downward to expose the option switch module.
4. Set the option switches to the desired setting.
5. Reassemble the bill validator in reverse order of disassembly.
6. Reapply power, the stacker motor should cycle.
7. Test for proper operation.

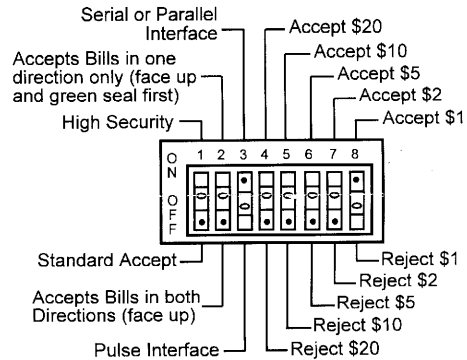
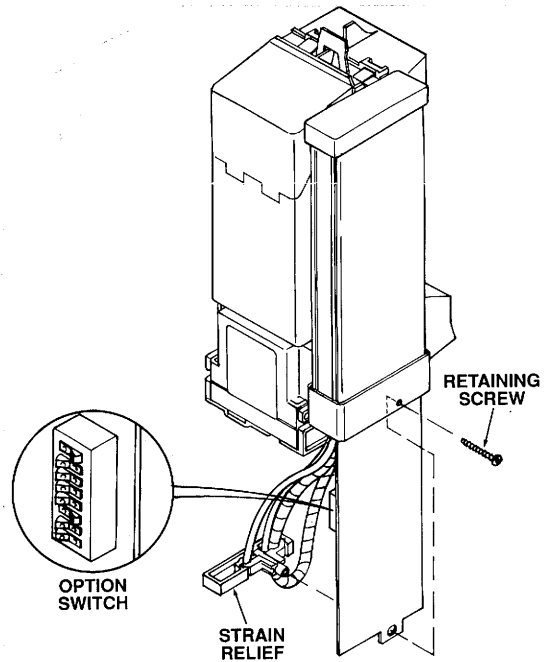

FIGURE 1

REMOVING ACCEPTED BILLS

Accepted bills may be removed by opening the "bill box" lid or by removing the bill box from the validator. If the bill box is removed, *make sure that it is fully latched in place when it is returned to the validator*

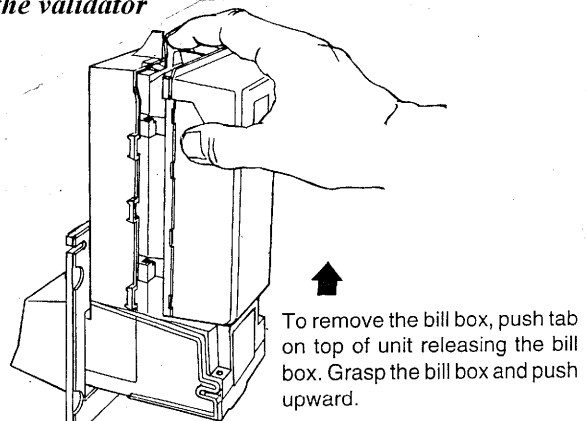

FIGURE 2

TROUBLE-SHOOTING:

Trouble-shooting can be achieved by reading flashes or blinks of light from the (red) LED located on the side of the logic board cover. These flashes can be seen through the grey smoked cover. (See *Figure 3*) During normal operation the "LED" will be a steady or constant red.

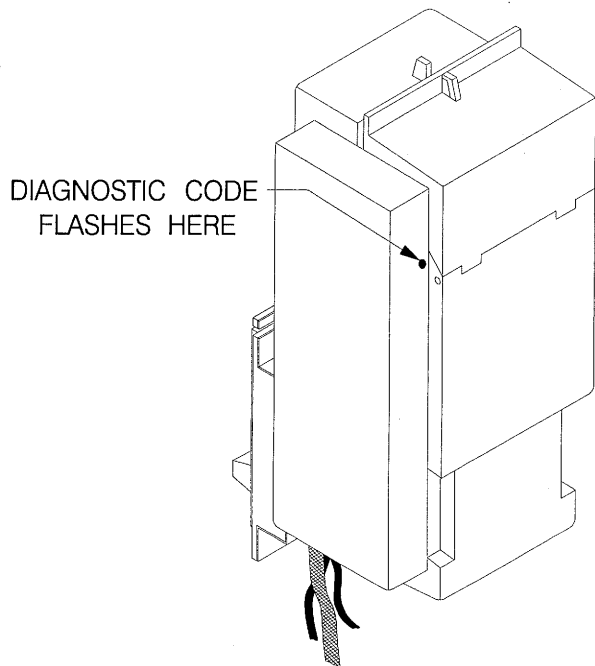
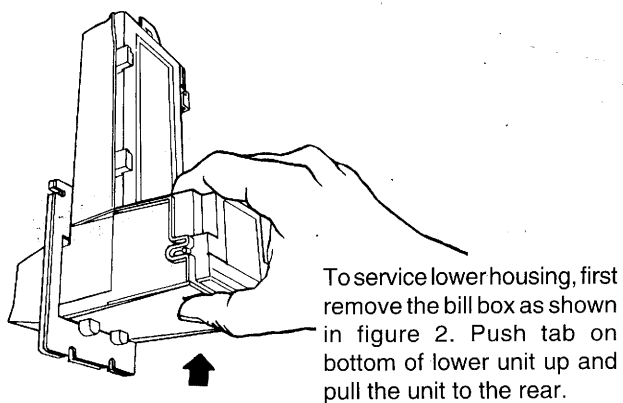

FIGURE 3

NO. OF FLASHES	DESCRIPTION OF DIAGNOSTIC CODES
No Flashes	Check Power and Harnessing to Validator
1	Bill Box Full
2	Bill Box Lid is open or not latched in place.
3	Check Bill Path
4	All Bill Accept Switches are Off
5	Bill Jam or Sensor Error
6 or more	Reset (Remove and Apply Power) or service required.

CLEARING JAMS & CLEANING:

Trapped bills, debris or dirt can result in poor bill acceptance or bill rejection. Remove the "bill box" and lower housing to clear trapped bills or debris. (See *Figure 4*) Clean the bill path plastic parts or belts with a cloth moistened with a mild soap and water solution. Clean the magnetic head and optic sensors using a swab and isopropyl alcohol. **Do not use any petroleum based cleaning solvents, scouring pads or stiff brushes for cleaning.**



To service lower housing, first remove the bill box as shown in figure 2. Push tab on bottom of lower unit up and pull the unit to the rear.

FIGURE 4

COMPLETE SELECTOR PANEL ASSEMBLY
(REPLACES PAGE #43 IN MANUAL #4203642)

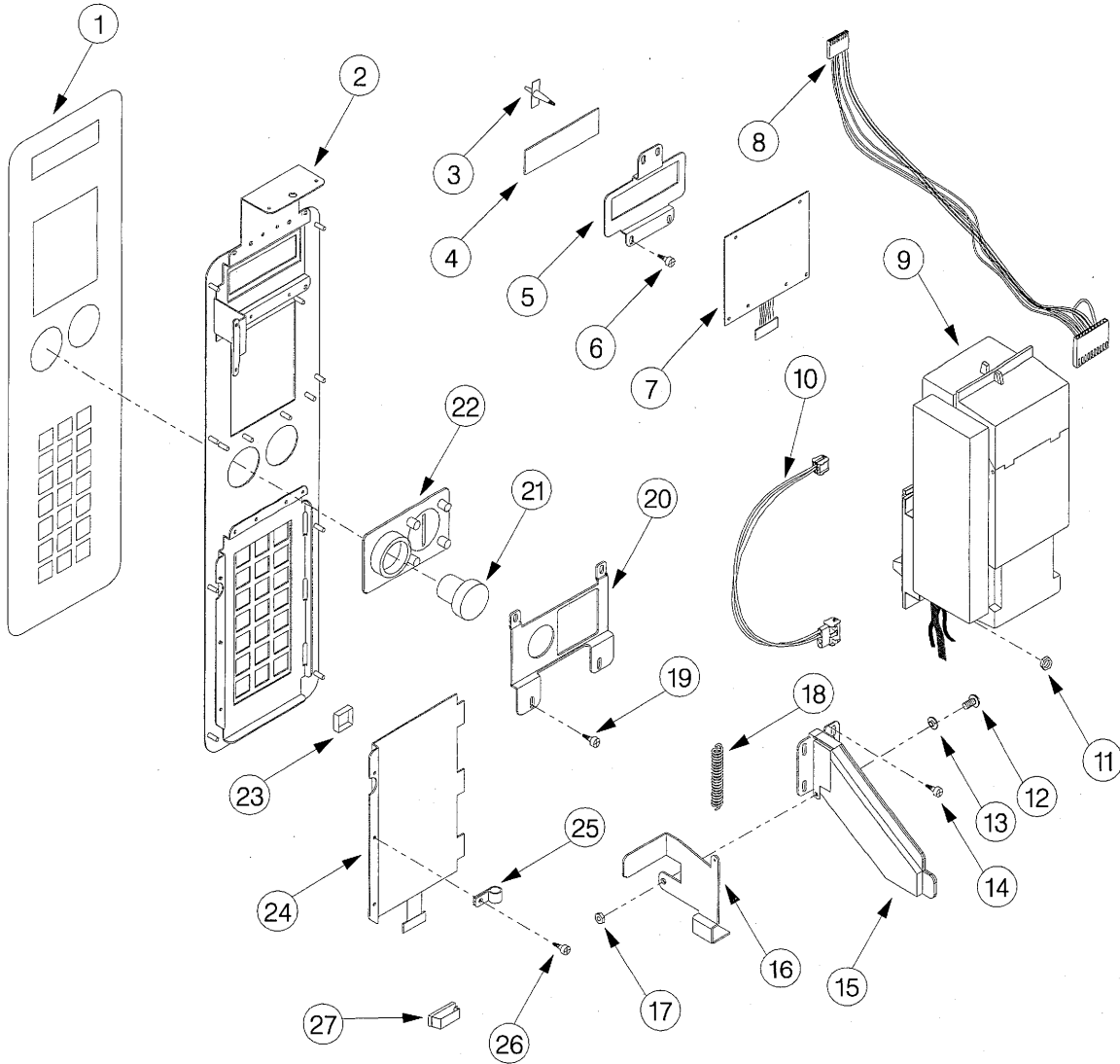

COMPLETE SELECTOR PANEL ASSEMBLY**(REPLACES PAGE #44 IN MANUAL #4203642)**

ITEM	PART NUMBER	QTY	DESCRIPTION
	1214166-002	1	COMPLETE SELECTOR PANEL ASSEMBLY
1	4207504	1	SELECTOR PANEL DECAL
2	1214152-001	1	SELECTOR PANEL WELD
3	4025723	4	CIRCUIT BOARD STAND-OFF
4	4200659	1	CREDIT DISPLAY LENS
5	4207312-001	1	CREDIT DISPLAY BRACKET
6	4050423	2	#8-18 X 3/8 PHIL PAN HD TYPE AB SCREW
7	4200660	1	CREDIT DISPLAY
8	4203684	1	VALIDATOR DATA HARNESS
9	4205536-124	1	VALIDATOR - COINCO BA32SA
10	4207595	1	VALIDATOR POWER HARNESS
11	8800956	6	#8-32 HEX NUT W/EXT WASHER
12	4050240	1	#8-32 X 3/8 PHIL PAN HD TYPE AB SCREW
13	4030100	1	BUSHING
14	4050423	4	#8-18 X 3/8 PHIL PAN HD TYPE AB SCREW
15	1212030	1	COIN INSERT WELD
16	4203191	1	COIN RETURN LEVER
17	4050511	1	#8-32 LOCK NUT
18	8376074	1	SPRING
19	4050423	2	#8-18 X 3/8 PHIL PAN HD M/SCREW
20	4207279-001	1	COIN INSERT RETAINER
21	4203187	1	COIN RETURN BUTTON
22	4203186	1	COIN INSERT/COIN RETURN MOLDING
23	4025741	21	PUSH BUTTON
24	1212028	1	KEYPAD ASSEMBLY
25	4060116	1	3/8" WIRE CLAMP
26	4050423	3	#8-18 X 3/8 PHIL PAN HD TYPE AB SCREW
27	4203696	1	RIBBON CABLE CLAMP

LANCE SCHEMATIC
P/N 4203690
REV. B

